

Cast Iron Pipes

**D
E
S
C
A
L
I
N
G**

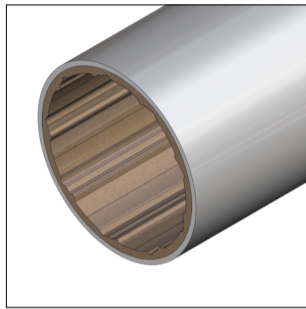

INTACT

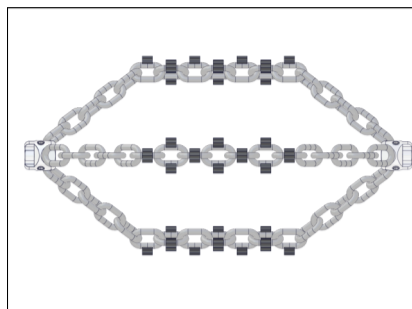

Original Chains

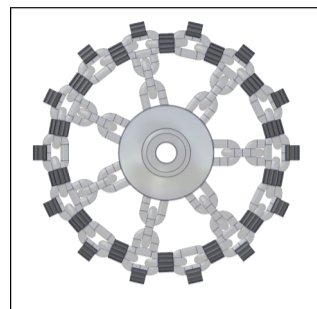

Cyclone Chains

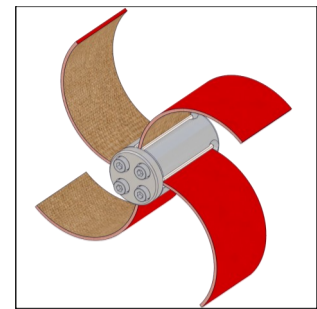

Smart Cutter

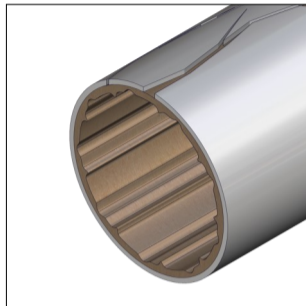

FRAGILE

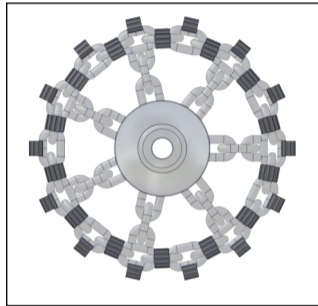

Cyclone Chains

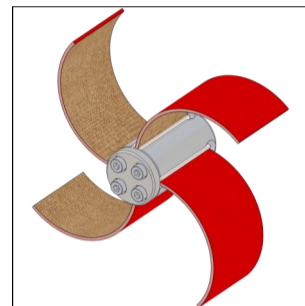

Smart Cutter

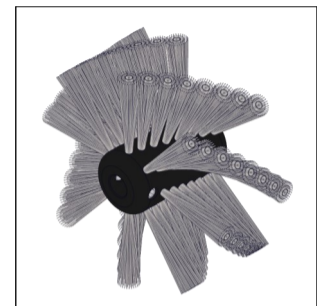

Wire Cleaning Brush

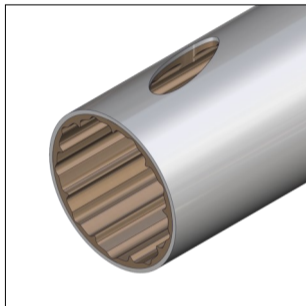

DAMAGED

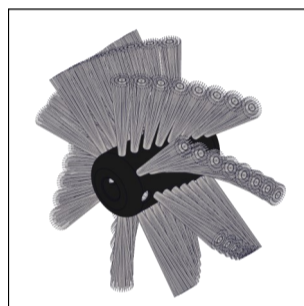

Wire Cleaning Brush

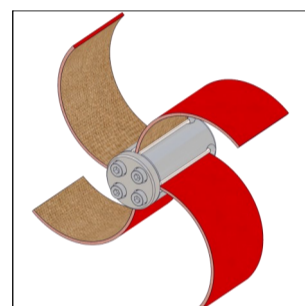

Smart Cutter

**S
P
E
C
I
A
L**

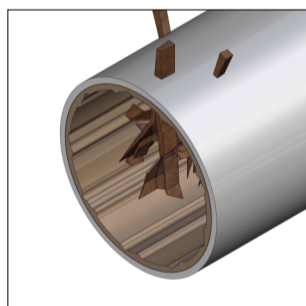

ROOTS

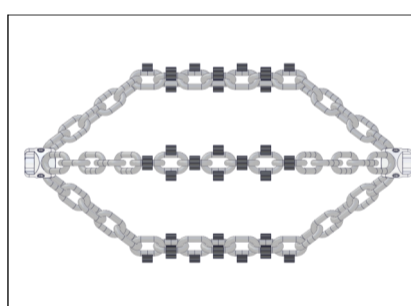

Original Chains

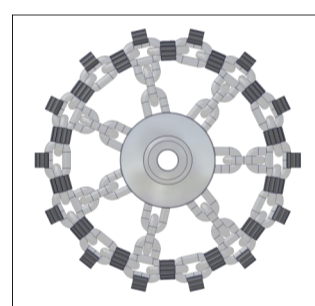

Cyclone Chains



Twister Mini

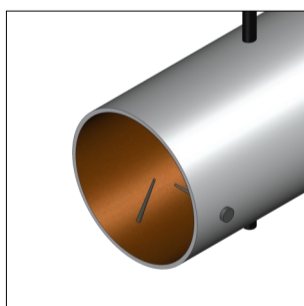

METAL

Refer to the Midi and Maxi Miller Range of Machines

Micro Miller

Shaft Diameter: **8 mm (1/3")**

Range: **12 m (39 ft)**

Pipe Diameter Range: **DN50 (2") to DN100 (4")**

Mini Miller

Shaft Diameter: **8 mm (1/3")**

Range: **17 metres (55 ft)**

Pipe Diameter Range: **DN50 (2") to DN100 (4")**

Available Tools

Original Chain (Standard)

Original Premium Chain

Cyclone Chain (Standard)

Cyclone Premium Chain

Smart Cutter

Wire Cleaning Brush

Twister Mini

Size Diameter

DN50 (2") to DN150 (6")

DN50 (2") to DN150 (6")

DN70 (3") to DN150 (6")

DN70 (3") to DN150 (6")

DN50 (2") to DN75 (3")

DN50 (2") to DN150 (6")

DN50 (2") & DN70 (3")